

capea



ta  
gar

INDUSTRIAS TAGAR, S. A.

El presente catálogo resume el espíritu empresarial de INDUSTRIAS TAGAR S.A., una empresa dinámica en constante mejora, tanto en el diseño de sus productos como en el servicio y atención al cliente. Nuestra experiencia en el equipamiento para la hostelería y las instalaciones nos sitúa en un lugar privilegiado dentro del sector. Nuestras nuevas inversiones en instalaciones y maquinaria nos permiten satisfacer las demandas del mercado, con el único propósito de dar mayor calidad a nuestros clientes,  
**todo un reto.**

This HOTEL TRADE AND INSTALLATIONS catalogue sums up the business spirit of INDUSTRIAS TAGAR S.A., a dynamic company undergoing constant improvement, both in the design of its products and in customers service and care. Our experience in equipment for the hotel trade and installations, has enabled us to obtain a privileged location within the sector. Our investment into installations and machinery enables us to satisfy market demands, with the single purpose of providing top quality to our customers,  
**a real challenge.**

L'actuel catalogue d'HÔTELERIE ET D'INSTALLATIONS résume l'esprit des INDUSTRIAS TAGAR S.A., une entreprise en continuelle amélioration aussi bien dans la description de ses articles comme dans son service à l'écoute de ses clients. Notre expérience en ce qui concerne l'hôtellerie et les installations nous situe en lieu privilégié dans ce secteur. Nos derniers investissements dans nos installations et machines nous permettent de satisfaire les demandes du marché avec comme seule finalité, offrir une meilleure qualité à nos clients,  
**tout un but.**



INDUSTRIAS TAGAR S.A. presenta:

capea

Diseño de: Pascual Salvador







## Versatilidad

PROGRAMA DE SILLERÍA PARA COLECTIVIDADES, CON ESTRUCTURA EN TUBO DE ACERO, ASIENTO Y RESPALDO EN MADERA DE HAYA NATURAL BARNIZADO O TAPIZADO.

LA GAMA SE COMPONE DE SILLA, SILLÓN FIJO Y CON ATRIL, BANCADA MULTIPUESTO Y SILLA Y SILLÓN CON RUEDAS.

# relaxformaciónespera

## Changeability

CHAIR PROGRAM FOR COMMUNITIES, WITH STEEL STRUCTURE TUBE, SEAT AND BACK IN VARNISHED WOOD TO HAVE NATURAL FACES OR UPHOLSTERED.

THE RANGE IS COMPOSED OF CHAIR AND ARMCHAIR, WITH WRITING-TABLET, BENCH MULTIPLACED AND CHAIR AND ARMCHAIR WITH WHEELS.

## Versatilité

PROGRAMME DE CHAISES POUR COLLECTIVITÉS, AVEC STRUCTURE TUBULAIRE, SIÈGE ET DOSSIER EN BOIS HÊTRÉ NATUREL VERNIE OU TAPISSÉ.

LA GAMME SE COMPONE DE CHAISE, ET FAUTEUIL, AVEC PUPITRE, BANC MULTI POSTE ET CHAISE ET FAUTEUIL À ROULETTES.

capea









relax





# mínimo espacio

MINIMUM SPACE ESPACE MINIMAL





formación







espera







capea

**DETALLES**

MODELOS Y DIMENSIONES

**ACABADOS**

DETAILS, MODELS AND DIMENSIONS, FINISHES

DÉTAILS, MODELES ET DIMENSIONS, FINITIONS





## ACABADOS DE CONTRACHAPADO

BEECH PLYWOOD /  
CONTREPLAQUÉ EN BOIS HÊTRE

**650** HAYA / BEECH / HÊTRE

**651** WENGUE

**650**

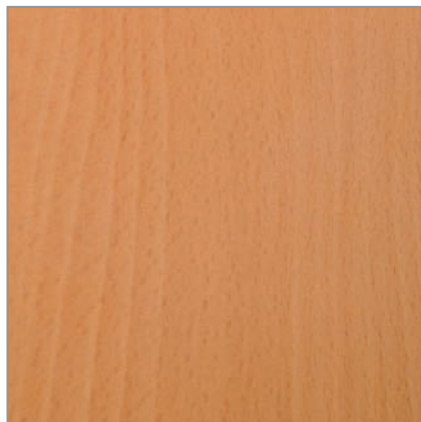

**651**



## DETALLES

DETAILS / DÉTAILS

**# 01** BRAZOS DE POLIPROPILENO  
POLYPROPYLENE ARMS  
BRAS EN POLYPROPYLÈNE

**# 02** TAPA INFERIOR  
LOWER COVER  
COUVERTURE INFÉRIEURE

**# 03** SILLAS CON PALA APILADAS  
CHAIRS WITH STACKABLE WRITING TABLET  
CHAIRES AVEC PELLE EMPILÉES

**# 04** PALA  
WRITING-TABLET  
TABLETTE ÉCRITOIRE

**# 05** RUEDAS DE PISADA BLANDA  
SISTEMA DE ELEVACIÓN A GAS

POLYPROPYLENE WHEELS  
GAS-OPERATED RAISING SYSTEM

ROUES EN POLYPROPYLÈNE  
SYSTÈME D'ÉLEVATION À GAZ

**# 06** TACO ESPECÍFICO  
SPECIFIC PLUG  
SOUS PATTES SPÉCIFIQUES

**# 01**

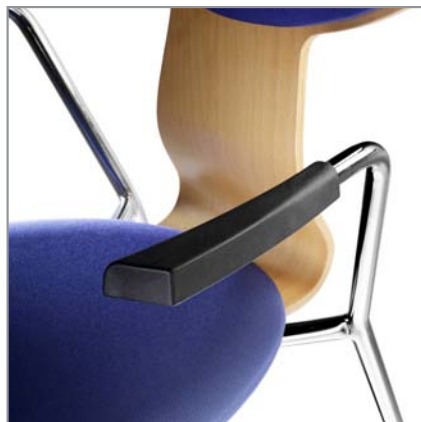

**# 02**



**# 03**



**# 04**



**# 05**



**# 06**



# capea

## MODELOS Y DIMENSIONES

MODELS AND DIMENSIONS      MODELES ET DIMENSIONS

### SILLA

CHAIR CHAISE

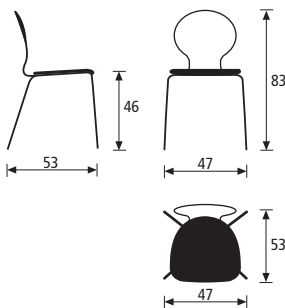

MOD. 510

Estructura en tubo de acero cromada o pintada en Epoxy-poliéster negro o gris texturado. Asiento y respaldo en contrachapado de haya barnizado, con otras opciones:  
A - Asiento tapizado.  
AR - Asiento y respaldo tapizados.

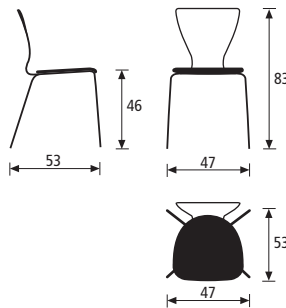

MOD. 520

Structure in Steel tube chromw-plated or coated in black or grey Epoxy-Polyester textured. Seat and back are made of varnish-coated beech plywood, including others options:  
A - Upholstered seat.  
AR - Upholstered seat and back.

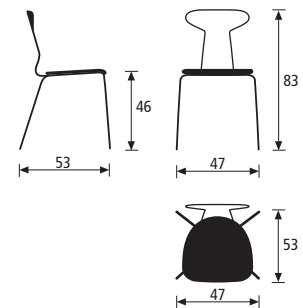

MOD. 530

Structure en tube d'acier chromé ou peint en epoxy-polyester noir ou texture gris. Siège et dossier contreplaqué en bois Hettré naturel verni avec d'autres options  
A- Siège tapissé.  
AR- Siège et dossier tapissés.

### SILLÓN

ARMCHAIR FAUTEUIL

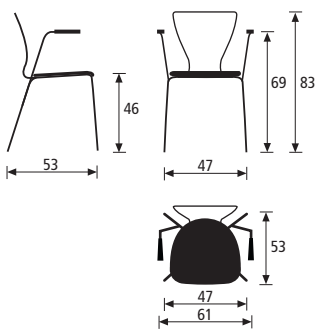

MOD. 511 / 521 / 531

Brazos de polipropileno color negro.  
Black polypropylene arms.  
Bras en polypropylène couleur noir.

### SILLA PALA

WRITTING-TABLET CHAIR CHAISE-ÉCRITOIRE

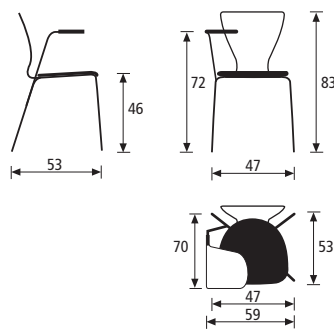

MOD. 512 / 522 / 532

Pala realizada en compacto de 10mm con sistema antipánico (derecha e izquierda).  
Black polypropylene arm. 10 mm compact writing-tablet chair featuring an anti-panic system (right and left).  
Tablette écrioire réalisée en compact de 10 mm. avec système anti-panique (droite et gauche).

### SILLÓN PALA

WRITTING-TABLET ARMCHAIR FAUTEUIL-ÉCRITOIRE

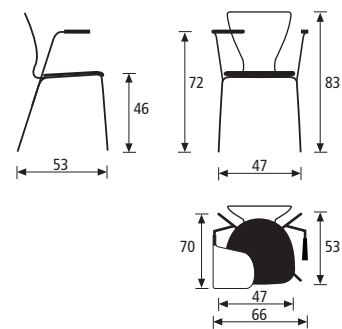

MOD. 513 / 523 / 533

Brazos de polipropileno color negro.  
Pala realizada en compacto de 10mm con sistema antipánico (derecha e izquierda).  
Black polypropylene arms.  
10 mm compact writing-tablet chair featuring an anti-panic system (right and left).  
Bras en polypropylène couleur noir.  
Tablette écrioire réalisée en compact de 10 mm. avec système anti-panique (droite et gauche).



Los dibujos, colores, medidas y modelos descritos podrán ser variados sin previo aviso.

The drawings, colours, dimensions and models can be modified without previous notification.

Les dessins, couleurs, mesures et modèles pourront être modifiés sans annonce au préalable.

## BANCADA

BENCH BANC

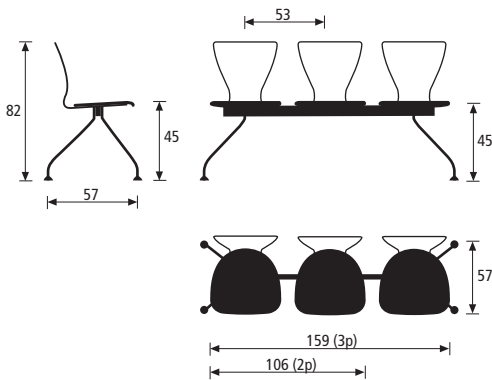

### MOD. 514 / 524 / 534

Estructura en tubo de acero pintada en Epoxy-poliéster negro o gris texturado. Patas de tubo de acero cromadas o pintadas en Epoxy-poliéster negro o gris texturado. Apoyo al suelo mediante nivelador. Asiento y respaldo en contrachapado de haya barnizado, con otras opciones:  
A - Asiento tapizado.  
AR - Asiento y Respaldo tapizado.

Structure in Steel tube coated in black or grey Epoxy-Polyester textured. Steel tube legs chromed or coated in black or grey Epoxy-Polyester textured. Floor support by levelling system. Seat and back are made of varnish-coated beech plywood, including others options:  
A - Upholstered Seat.  
AR - Upholstered Seat and Back.

Structure en tube d'acier peint en epoxy-polyester noir ou texture gris. Pattes en tube d'acier chromées ou peint en epoxy-polyester noir ou texture gris. Appui au sol même niveau. Siège et dossier contreplaqué en bois Hêtre naturel verni avec d'autres options:  
A- Siège tapissé.  
AR- Siège et dossier tapissés.

## BANCADA CON BRAZOS

BENCH WITH ARMS BANC AVEC REPOSE BRAS

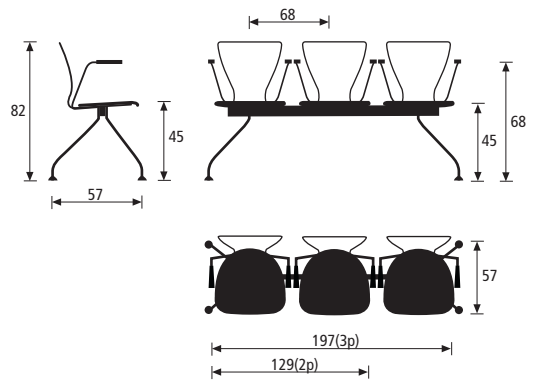

### MOD. 515 / 525 / 535

Brazos de polipropileno color negro.

Black polypropylene arms.

Bras en polypropylène couleur noir.

## SILLA DE RUEDAS

WHEEL CHAIR CHAISE À ROULETTES

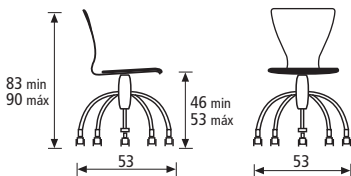

### MOD. 516 / 526 / 536

Base de ruedas en tubo de acero cromada o pintada en Epoxy-poliéster negro o gris texturado. Ruedas de pisada blanda. Sistema de elevación a gas. Asiento y respaldo en contrachapado de haya barnizado, con otras opciones:  
A - Asiento tapizado.  
AR - Asiento y Respaldo tapizado.

Whellbase is made of chrome-plated steel tube, or black or grey Epoxy-Polyester textured. Polypropylene wheels. Gas-operated raising system. Black polypropylene arms. Seat and back are made of varnish-coated beech plywood, including other options:  
A- Upholstered seat.  
AR-Upholstered seat and back

Base avec roues en tube d'acier chromé ou peint en Epoxy-Polyester noir ou texture grise. Roues en polypropylène. Système d'élevation à gaz. Bras en polypropylène couleur noir. Siège et dossier en hêtre vernis, avec d'autres options:  
A - Siège tapissé.  
AR - Siège et dossier tapissés.

## SILLÓN DE RUEDAS

WHEEL ARMCHAIR FAUTEUIL À ROULETTES

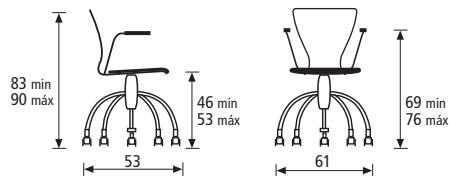

### MOD. 517 / 527 / 537

Brazos de polipropileno color negro

Black polypropylene arms.

Bras en polypropylène couleur noir.





capea

Diseño de: Pascual Salvador

livingtagar

capea

Distribuido por:



Polígono del Henares.  
Avda. de Roanne, 69-70.  
19004 GUADALAJARA-España  
Tel.: 00 34 - 949 24 77 80  
Fax: 00 34 - 949 21 70 41  
e-mail: i.tagar@tagar.es

[www.tagar.es](http://www.tagar.es)



INDUSTRIAS TAGAR, S. A.

